

Manille Ø16HR / Ø16HR Shackle
Poids/weight : 518g

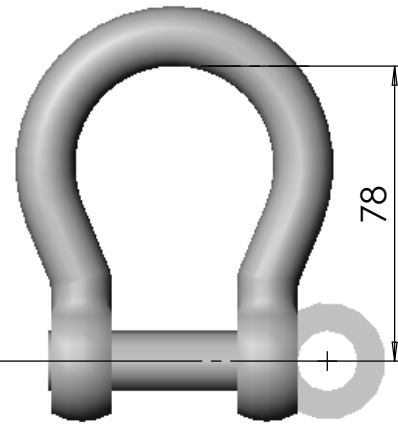

Cosse / thimble
Poids/weight : 187g

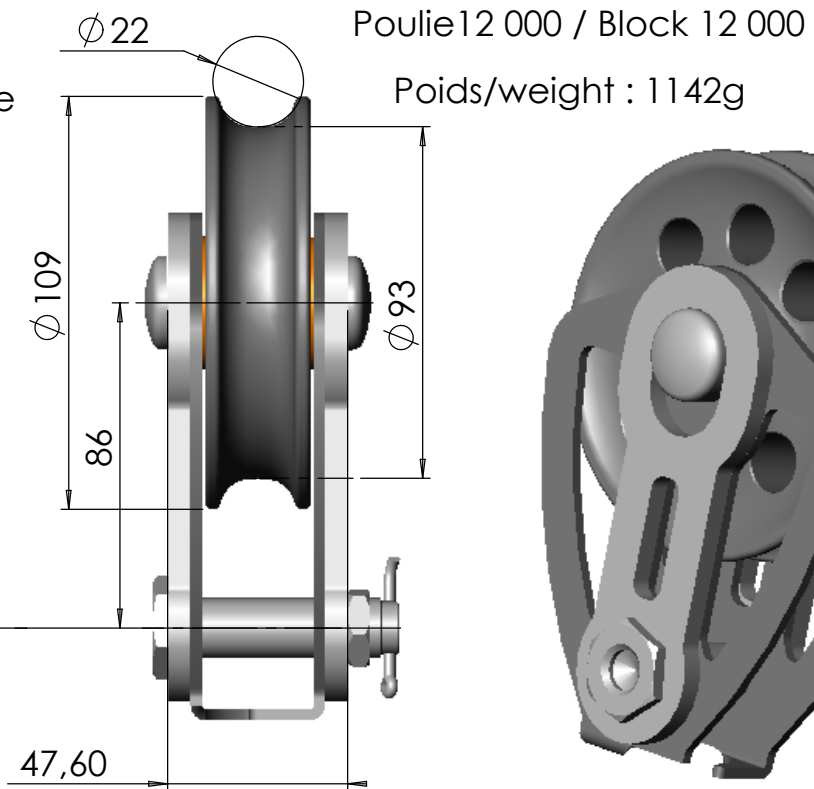

Poulie 12 000 / Block 12 000
Poids/weight : 1142g

Poids/weight : 1320g

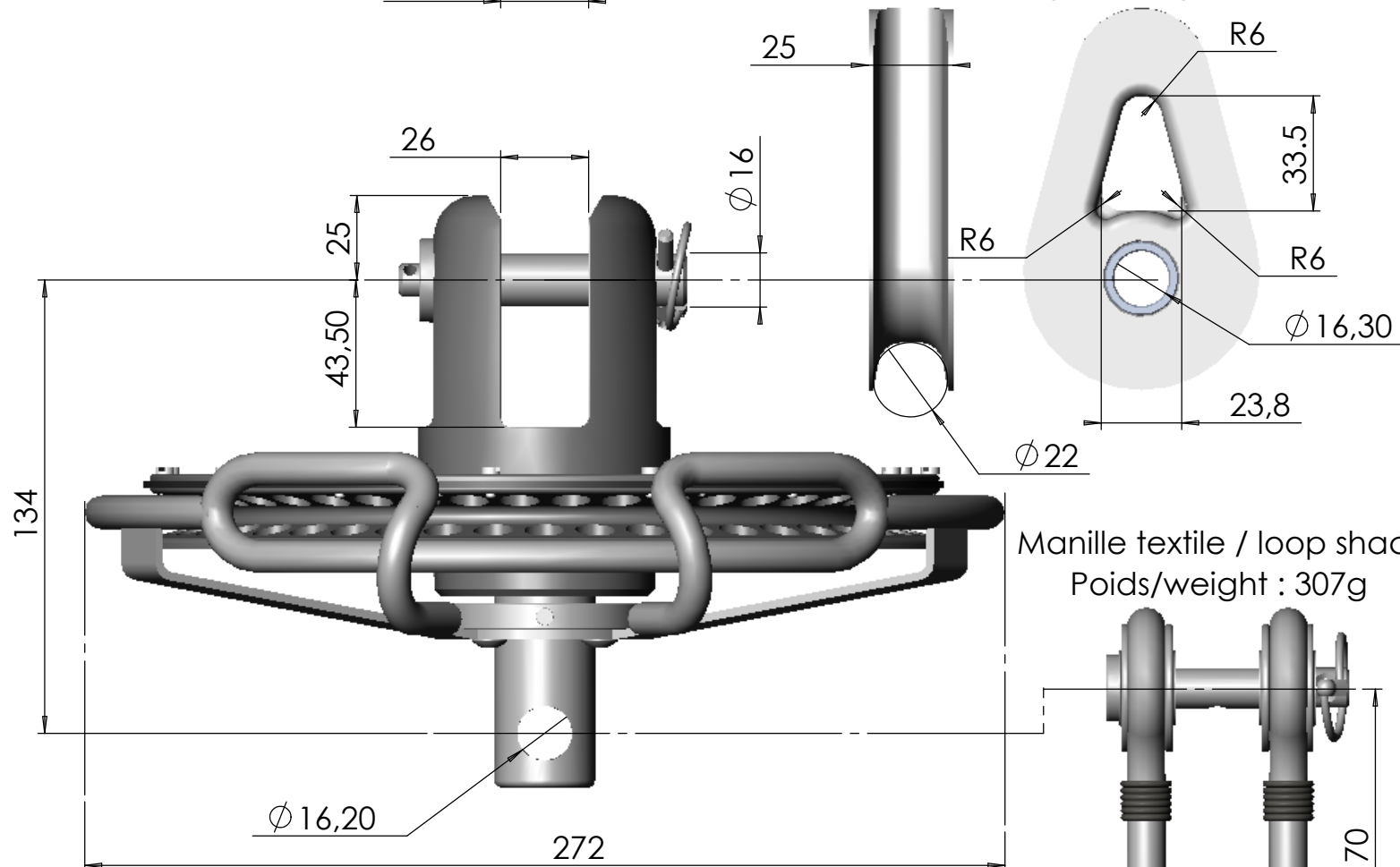

Manille textile / loop shackle
Poids/weight : 307g

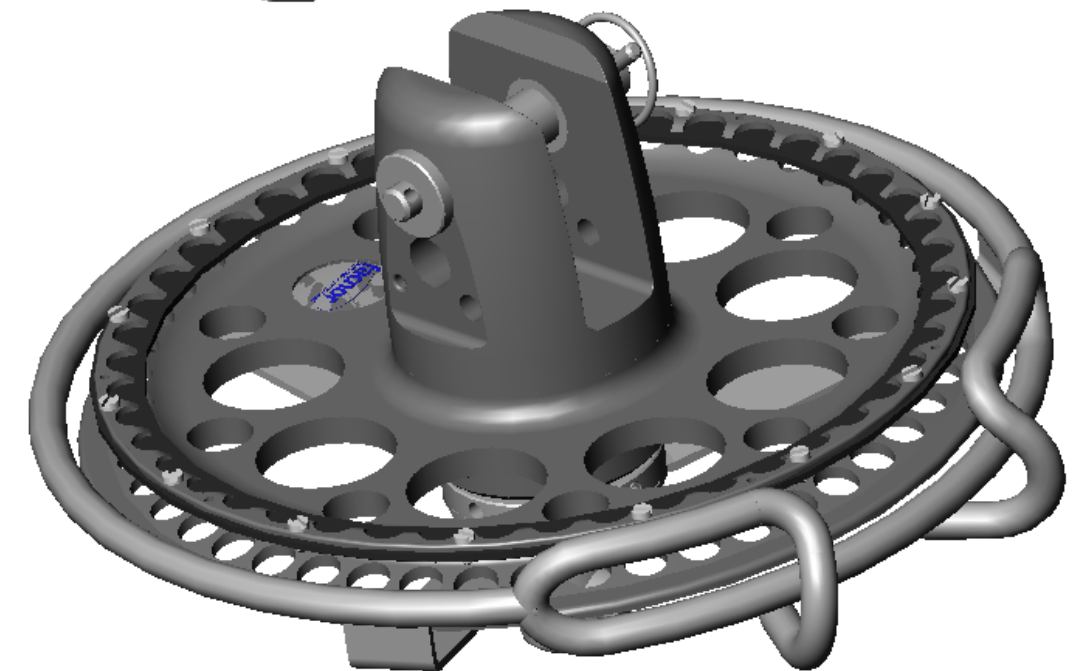
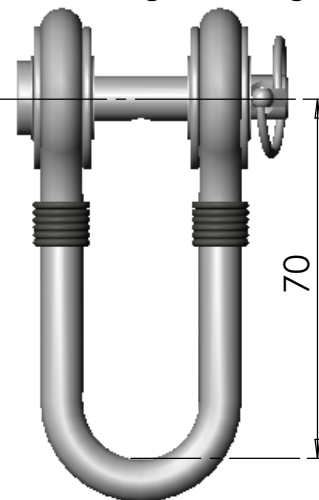

Poids/weight : 3040g

Charge de travail / Working load: 12 000Kg

Ind	Date	Auteur	Vérificat°	Description de la modification
FX 12 000 - ENCOMBREMENT				A3
				Ech: 1:1
Date:	Tol. Gén.:	Etude:		 FACNOR S.A.S. Parc d'Activités - B.P. 222 F-50550 SAINT-VAAST-LA-HOUGUE tel. +33 (0)2 33 88 50 22 fax. +33 (0)2 33 23 14 27
Auteur:	Matière:	Prod°:		
Appr.:	Finition:	Indice:		

Ce plan est la propriété intellectuelle de FACNOR SAS. Il ne peut être divulgué à des tiers sans notre autorisation écrite, ni servir à d'autres fabrications.